

780-1080nm High Power Circulator(TGG)

Features

- Low insertion loss
- High return loss
- Excellent environmental stability

Application

- Optical fiber amplifier
- Medical instruments
- Test instrument

Specifications

Parameter	Unit	Value
Central wavelength	nm	1064, 1030, 980, 780 or Specified
Operating wavelength range	nm	±5
Typical peak Isolation	dB	25
Minimum isolation @23°C	dB	22
Typical insertion loss@23°C	dB	1.3
Maximum insertion loss@ 23°C	dB	1.5
Minimum extinction ratio@23°C(Polarization-maintaining Fiber type)	dB	20
Maximum polarization dependent loss@23 °C (Single mode Fiber type)	dB	0.15
Minimum return loss(input/ output)	dB	45
Minimum crosstalk	dB	45
Maximum average power (include port1 andport2)	W	1, 2, 5, 10, 20 or Specified
Maximum pulse value power	kW	10 or Specified
Maximum tensile load	N	5
Package dimensions	mm	64x28x26
Operating temperature	°C	+10~+50
Storage temperature	°C	0~+60

When using the Connector, the processing power is only 1W, the Insertion loss is 0.3dB higher, the return loss is 5dB lower, and the extinction ratio is 2dB lower. The Connector key is aligned with the slow axis.

Package dimensions

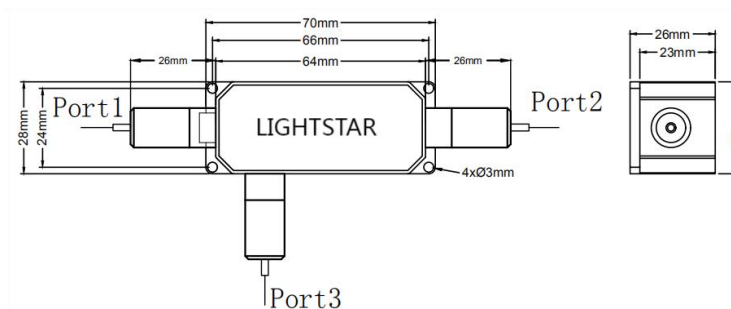

Ordering information

HPMCIR/HPICIR-①①①①-②-③-④④④-⑤-⑥-⑦-⑧-⑨

- | | | | |
|---|---|--|---|
| ①①①①: Wavelength
0780=780nm
1064=1064nm
SSSS=Specify | ②: Port type
1=1*2 | ③: Working axis
B=Biaxial operation
F=Fast axle cutoff | ④④④: Fiber type
001=PM1550
004=Hi1060
SSS=Specify |
| ⑤: Package dimensions
4=64x28x26mm
S=Specify | ⑥: Length
H=0.5m
1= 1.0m
S=Specify | ⑦: Pigtail type
1=250um bare fiber
2=900um loose tube
S=Specify | ⑧: Connector
0=None
1=FC/UPC
2=FC/APC
S=Specify |